



polkaudio
The Speaker Specialists[®]

**POLK AUDIO
5601 METRO DRIVE
BALTIMORE, MARYLAND 21215
(800)377-7655**

**POLK AUDIO EUROPE LTD.
TYTTENHANGER HOUSE
COURSERS ROAD
ST. ALBANS AL4 OPG
GREAT BRITAIN
TEL: 1727.827311**

**POLK AUDIO GERMANY
UNTERTUERKHEIMER STR. 24
D - 66117 SAARBRUECKEN
GERMANY
TEL: (49) 681 5800 888**

<http://www.polkaudio.com>

"Polk Audio" and "The Speaker Specialists" are trademarks of Britannia Investment Corporation used under license by Polk Audio Incorporated.

subwoofer

**Polk Audio
EX Series II** Owner's Manual

ATTACH YOUR RECEIPT
HERE AND FILE FOR
FUTURE REFERENCE
X

POLK AUDIO – A HISTORY OF EXCELLENCE

Polk Audio was founded in 1972 by Matthew Polk and George Klopfer. Their dream was to make speakers with the performance of the world's best speakers, at a reasonable price. They did so by applying scientific principles to speaker design and by concentrating solely on the speaker business. That is how Polk became known as "The Speaker Specialists."

Today Polk Audio is still headquartered in Baltimore, Maryland and is one of the world's largest manufacturers of home and car loudspeakers. Polk's research has yielded over 20 patents for advances in loudspeaker performance and value. Polk speakers have earned the praise of audio experts the world over, as well as dozens of awards for innovative, high-quality design. Polk Audio speakers are sold in over 50 countries and in audio/video specialist retail locations throughout the US.

Founders Matthew Polk and George Klopfer still work alongside 300 dedicated Polk team members to bring you the best speakers you can buy.

THE STORY OF DYNAMIC BALANCE®

Your new Polk speakers employ Dynamic Balance, a technology which came out of a joint research project between Polk Audio and Johns Hopkins University. This laser imaging research enables us to view the entire vibrating surface of a driver or tweeter, allowing us to observe the resonances which develop on speaker cones as they move. These resonances are the root cause of frequency response distortions.

As an x-ray enables a physician to discover the root cause of a symptom and thereby prescribe the right treatment for a cure, this laser imaging technique allows Polk engineers to find the right combination of high-tech materials, geometry and construction techniques to tune out the offending resonances. The benefit of Dynamic Balance is the dramatic improvement in the sound quality of our speakers, which every listener can appreciate. You no longer have to choose between excellent bass and smooth, clear midrange and highs. Now you can have it all, thanks to Dynamic Balance technology.

A WORD FROM MATTHEW POLK

Dear Music Lover,

Thank you for purchasing Polk Audio speakers. Designing and building speakers is more than just a business for the people of Polk Audio – it is our passion. We are all dedicated to your complete satisfaction and delight.

Your new Polk speakers include the latest loudspeaker technology to assure outstanding performance and unmatched quality. Please take a moment to read through this manual for information on getting the greatest enjoyment from these fine instruments.

We make a wide variety of automotive loudspeakers, including factory replacements, coaxes, component systems, tweeters and subwoofers. If you would like more information on building the Polk car system of your dreams, consult your Polk Audio dealer or call our Customer Service Department at 1-800-377-POLK (7655) from 9am to 5pm, Eastern Time, Monday through Friday.

Sincerely,



Matthew S. Polk

Co-founder and Chairman

EX SERIES II SUBWOOFER FEATURES:

The EX Series II subwoofers use the latest technologies and highest quality materials to provide you with the best bass response and greatest reliability possible. The EX Series II subwoofers have been optimized to give skull-collapsing performance from a wide variety of enclosure types. Some of their design elements are:

- 1mm thick mineral filled polymer composite cones – ultra stiff and strong to withstand the enormous pressures generated inside subwoofer enclosures without cone breakup and distortion.
- Injection molded polypropylene dustcap – prevents distortion due to the build up of air pressure behind the cap.
- Rubber surrounds – provide a much tighter and more durable air seal behind the cone than foam, paper or cloth surrounds, for deep, tight, quick bass. In addition, rubber surrounds do not dry rot like foam surrounds.
- Four layer, 2" voice coil (EX10 and EX12 only) – handles heat generated when your amp is really cranking.
- Vented pole piece – lets air circulate over the voice coil to keep it cool and in control even when the bass is really thumping.

BUILDING YOUR OWN SUBWOOFER ENCLOSURE

Since the subwoofer enclosure is so critical to getting the best performance from your EX subs, you should ask yourself the following questions:

1. Do I really enjoy working with my hands?
 2. Do I have good woodworking and mechanical skills?
 3. Do I have or have access to woodworking and electrical tools?
 4. Do I have a solid understanding about musical reproduction in an automobile?
- If you answered "NO" to any of the above questions, we recommend you choose one of these two possible alternatives. First, you may choose a pre-built subwoofer enclosure available from companies like Obcon, ADD and Q-Logic or an enclosure kit from BassLine and other manufacturers. The second alternative is to have your authorized Polk Audio dealer design and build a woofer box for you.
 - If you answered "YES" to all of the above, let's review some basics before you begin. Effective planning will help ensure that your system performs the way that you want it to. Every car is different, and everyone has slightly different musical tastes. You need to make informed decisions before you begin to build your system. Polk EX subwoofers are designed to work in a wide variety of enclosures, and each enclosure design has a unique list of pros and cons. The following is the basic information about the most popular automotive subwoofer enclosures.

It is not possible to provide all of the information for enclosure options here. This manual will give you enough information to build a great sounding enclosure. If you are interested in a greater choice of enclosure designs, your Polk EX Series II dealer has extensive experience designing woofer boxes and will be more than happy to work with you. If you prefer, you can call our Customer Service Department from 9AM to 5PM, Monday through Friday, Eastern Time at (800)377-7655 or email us at polkcs@polkaudio.com.

ACOUSTIC SUSPENSION ENCLOSURES

The acoustic suspension cabinet is a sealed airtight box, and is the simplest, easiest box to build. It is a very predictable enclosure with easily calculated parameters and a smooth natural sound. Properly built acoustic suspension cabinets have a reasonably flat frequency response that begins rolling off at 12 dB per octave at the frequencies below its cabinet resonance. This works very well inside a car because of a natural phenomenon called “room gain” or “transfer function” that gives you a 12 dB per octave increase in bass frequencies. You can roughly calculate at what frequency this gain begins by using the equation $F = 565 / L$. F is the frequency at which bass gain begins, and L is the longest dimension of your “room”. If, for example, you measured the longest dimension in the interior of your car as 5.65 ft., the room gain begins at $565 / 5.65$ or 100 Hz. If your goal was perfectly flat frequency response, you would design your cabinet for this particular car to have a resonance frequency of 100 Hz. Since most people want more bass than a flat frequency response yields, tuning the cabinet at a lower frequency, say 50 Hz, would give you a gain of 12 dB per octave between 100 and 50 Hz and flat response from 50 Hz down. The larger the cabinet, the lower the resonant frequency, and the lower the efficiency. Two identical systems will sound very different in a Honda vs. a Cadillac. The bigger the car, the lower the frequency at which room gain begins.

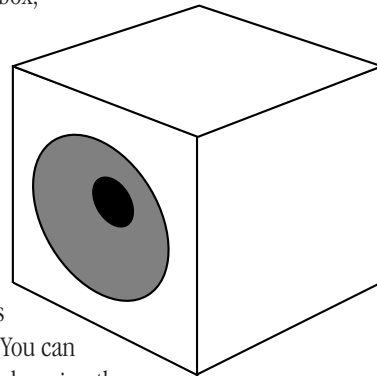

FIGURE 1.

INFINITE Baffle

Also known as free air enclosures, this essentially means mounting your woofers in the rear deck of your car, and not building a box around the speakers. At first glance, this would seem to be a very easy way to install your new speakers, but many problems can occur if this is not done exactly right. In the acoustic suspension design described above, the box is providing two major functions: first, the air that is sealed within the box acts as a spring to help support the suspension of the speaker. As the woofer cone moves in towards the box, the air in the box pressurizes; and as the cone moves out a vacuum forms. This helps to keep the cone from traveling too far and destroying itself. An Infinite Baffle design has no box; therefore, it has no trapped air behind the speaker to act as a spring. If your speakers are not specifically designed for infinite baffle use they can be damaged. Your new EX Series II woofers are designed for use in enclosures and are not recommended for infinite baffle use. The second thing that a sealed box provides is sound wave isolation created from the front of the speaker cone due to the waves that are created from the back of the speaker cone. If the two wave fronts are not isolated from each other they will mix

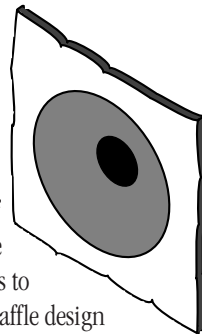

FIGURE 2.

together and cancel themselves out, making no bass at all. If you plan on building an infinite baffle system you must plan on sealing all of the air passages between the trunk and the passenger compartment (not an easy job). Also the metal used on the rear decks of cars does not make for a very good baffle board; the metal will tend to resonate and again cancel out the bass frequencies. You should plan on mounting your woofers on a non resonant wooden baffle. A properly designed infinite baffle enclosure will roll off at 6 dB per octave below cabinet (speaker) resonance, and will have a very smooth frequency response. The infinite baffle is the least efficient box design.

TUNED PORT ENCLOSURES

The tuned port enclosure is similar to the acoustic suspension box except that it uses a port to take the back wave from the speaker and “tune” it to reinforce the front wave. A system becomes more efficient when the frequencies of the port and the front wave are in phase. It is absolutely critical that the dimensions of the box and the port are perfect, or the back and front waves will cancel each other out, reducing your bass output. Tuned port enclosures tend to be peaky in the bass, and many people (particularly Bassheads) like the punchiness of the sound. Tuned port enclosures roll off at a very steep 18 dB per octave below cabinet resonance, which means that the room gain of the car will not help to extend the lowest of frequencies. In addition, the woofer becomes “unloaded” below the tuning frequency of the port and very loud musical information below these frequencies can damage a woofer.

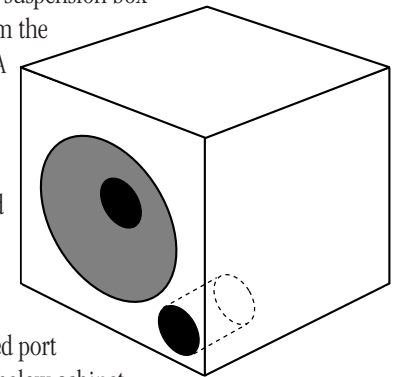

FIGURE 3.

BAND-PASS ENCLOSURES

Band-Pass boxes can be built in a near infinite amount of configurations. They incorporate at least two individual chambers and are by far the most complicated box to model and build. The theory behind band-pass boxes is to limit the frequencies produced by the subwoofer, thereby making it more efficient in the frequencies that it produces. A by-product of this efficiency is that it is often possible to build a band-pass box much smaller than its equivalent acoustic suspension box and get the same quantity of acoustic output. If you have a very small car with limited room for a subwoofer box, a band-pass box may be a good choice. The downsides of the band pass box are numerous. First, the construction must be flawless, any airleaks or rattles will seriously degrade performance.

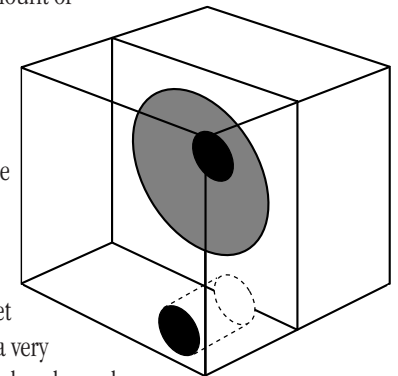

FIGURE 4.

Second, designing band-pass boxes is as much art as science, just because a computer program says that a certain design will work is no guarantee that you will like the performance of the finished design. Third, all subwoofer enclosures exhibit a phenomenon known as “group delay”. It means that the sounds from the subwoofer will lag in time from the sounds created by your high frequency speakers. This causes a smearing of the sound and in worst cases a ping-pong effect from the highs in the front of your car to the bass in the rear. Band-pass boxes are especially prone to long group delays. Finally, the pressures and vacuums formed within a band-pass box can be extremely high, if the subwoofer you are utilizing does not have a very stiff cone. It can buckle under the high pressures, making very bad noises. The Polk EX subwoofers utilize 1mm thick mineral filled cones, and are extremely well suited for use in band-pass enclosures.

TOOLS YOU WILL NEED TO BUILD YOUR ENCLOSURE

If you have decided to build your own enclosure for your Polk EX subwoofers, here is a list of the tools you should have available.

- Calculator
- Assorted drill bits
- Screwdriver bit for drill or manual screwdriver
- Circular saw
- Tape measure
- Drill - electric or cordless
- Jig saw

PARTS YOU WILL NEED TO BUILD YOUR ENCLOSURE

There are three choices of enclosure material:

1. Particle board
2. Medium density fiberboard (MDF)
3. Marine grade plywood

These materials range in price as well as availability. Particle board is the most common, least costly, and can be purchased at most hardware stores. MDF and marine grade plywood, although preferable, are usually much harder to find, and more costly. Whichever you choose, we recommend that its thickness be 3/4". This will provide the rigidity necessary for optimum performance.

If you have never built an enclosure before, we are going to try to make this as easy and painless as possible. If you have built enclosures before, you can skip this section and go right to the specification page to get the technical parameters.

1. Wood (particle board, MDF, or marine grade plywood) 4' x 8' x 3/4" sheet
2. Wood glue (one bottle)
3. 1 1/4"x #8 wood screws (one box)
4. Caulking gun and silicon caulk (two tubes)
5. Terminal cup (one per speaker) available at electronic parts stores
6. Speaker wire
7. Carpet (optional)
8. Grilles to protect your subwoofers (optional)
9. Solderless speaker connectors (available at electronic parts stores)

DESIGNING YOUR POLK EX SUBWOOFER ENCLOSURE STEP BY STEP

- 1.) How much room do you have to work with in your car or truck?
- 2.) Which of the above enclosures sounds the best to you?

When designing your subwoofer enclosure, the first thing you need to figure out is just how large an enclosure will fit in your vehicle. When an enclosure is going in the trunk of a car, you first need to measure your trunk to find the maximum height, width, and depth available. Pay attention to trunk hinges and tension bars. If your enclosure is going in an area other than a trunk, make sure you check for similar obstructions. After measuring, subtract 1.5" from each dimension. This compensates for the thickness of the material you use, and will give you your usable (internal) dimensions. Record these dimensions in the space below for future reference.

<u>Maximum dimensions</u>	<u>Usable dimensions</u>
Height: _____ inches	(Minus 1.5 inches) = _____ inches
Width: _____ inches	(Minus 1.5 inches) = _____ inches
Depth: _____ inches	(Minus 1.5 inches) = _____ inches
	Usable volume = _____ cubic inches
	Usable volume = _____ cubic feet

Multiply your usable Width x Height x Depth. The product will be the usable (internal) volume of your enclosure in cubic inches. Divide this number by 1728 (the number of cubic inches in a cubic foot). This will give you the internal volume in cubic feet. Divide your internal cubic feet by 2 (only if you are using a pair of EX subwoofers). Compare this number to the chart on page 14 of this manual. Choose the recommended enclosure which is closest in size. Now that you have all of your needed dimensions, you can begin cutting your wood. From the above chart you can tell how big each piece of wood should be. Here's a sample enclosure.

<u>Maximum dimensions</u>	<u>Usable dimensions</u>
Height: <u>17.5</u> inches	(Minus 1.5 inches) = <u>16</u> inches
Width: <u>35.5</u> inches	(Minus 1.5 inches) = <u>34</u> inches
Depth: <u>11.5</u> inches	(Minus 1.5 inches) = <u>10</u> inches
	Usable volume = <u>5440</u> cubic inches
	Usable volume = <u>3.15</u> cubic feet

By looking on the chart at the bottom of page 14 of this manual, you'll find that this usable volume is slightly more than double the recommended volume for a single EX12, in either a sealed or vented enclosure. Assuming that you will be using a pair this will work out well. If you are using a single subwoofer, you can cut your width in half. Since we will be using a pair of EX12 subwoofers for our sample enclosure, we now need to determine the center divider displacement and the resulting total usable volume. This can be figured out by multiplying the height x depth x thickness of the divider, and subtracting that number from the total usable cubic inches. Using the example above yields the following result:
 $[5440 \text{ in}^3 - (16" \times 10" \times 3/4")] = [5440 \text{ in}^3 - 120 \text{ in}^3] = 5320 \text{ in}^3$ total usable volume.

FIGURE 5.

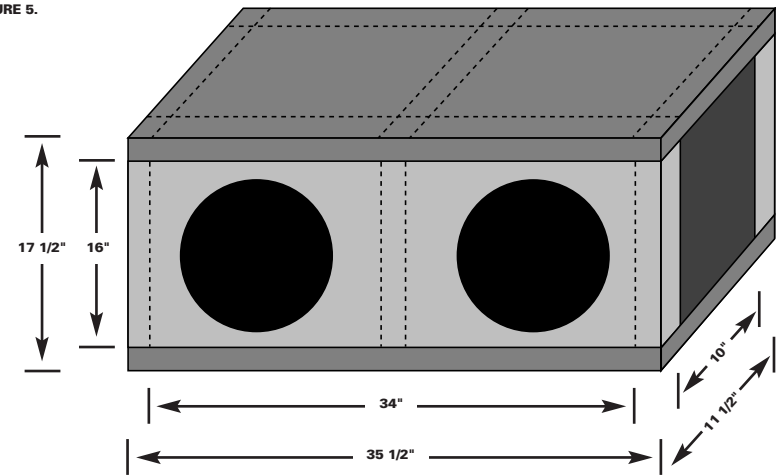

You now have all the dimensions you need to begin cutting out your wood. The illustration above shows a diagram of the enclosure with all the panel sizes that need to be cut.

After you have cut all of the wood, it's time to start assembling your enclosure. Before you assemble your enclosure there are a few things we recommend doing. You will need to cut out the hole for your EX subwoofer and your terminal cup. The terminal cup is a connector that allows you to plug and unplug the wires from your amplifier into the enclosure. You may want to have a friend help you with assembly since it's hard to hold the pieces together and assemble them at the same time. When building your subwoofer enclosure, we suggest that you use wood glue in combination with wood screws for the strongest joint. We also suggest that you use one screw about every three inches along the seams of your enclosure. Assemble the enclosure as shown in the above diagram, but leave one side off. We suggest that you leave off the baffle board. This will allow you to seal your enclosure more easily, and an air-tight seal is crucial! The best way to insure an air-tight seal is to seal the inside of your enclosure with quality silicone caulk. This also includes sealing around your input terminal cup, and, if you are using a ported enclosure, around your port. It is not advised to use silicone around your subwoofer when mounting it to the baffle. Instead, we recommend using the foam gasket weather stripping supplied with your EX subwoofer. When mounting your subwoofer to the baffle board, pre-drill your mounting holes using the template supplied. This will make the mounting of your subwoofer easier and will help prevent damage to your subwoofer from a slip of the drill. When securing your subwoofer to the enclosure we recommend using bolts and tee-nuts, but if you prefer, you can use wood screws. Whichever you use, make sure it is at least 1.25" long. This will insure a good grip into the wood.

When building a ported enclosure we suggest that, whenever possible, you locate the port on the same baffle as your subwoofer. Your port should be unobstructed both in front of and behind it by at least 1 to 2 times the diameter of the port. If, on the inside of your enclosure, the port comes within 1 to 2 times its diameter of the rear wall, you will need to “bend” your port tube. If you are using PVC pipe you can either cut your port on a 45 degree angle and rotate the cut portion by 90 degrees, and glue (using PVC cement) or you could buy a 90 degree elbow from your local hardware store. If you are using a card board port tube you will have to use the cut and rotate method. Since you will be unable to install a “bent” port from outside the enclosure, you can now see why we recommended leaving your baffle board off until last.

Finally, one last thing you could do to your enclosure before installing it is to stuff it. The primary reason for stuffing an enclosure is to “trick” the woofer into thinking that the enclosure is larger than it actually is. You would want to do this if you build your box smaller than the recommended size. By stuffing the box you can build the box as much as 10% smaller than recommended and still achieve the same net result as the full size unstuffed box. The easiest way to do this is to use dacron pillow stuffing which can be purchased from craft stores fairly inexpensively. The rule of thumb for stuffing your enclosure is 1 pound of dacron per cubic foot. When putting the dacron into your enclosure, do not pack it in, rather place it evenly around the inside of the enclosure. When stuffing a ported enclosure, it is important not to obstruct the port with the dacron.

Although your new EX subwoofers were designed to work in a wide variety of enclosures and configurations, we have included only the most popular ones. For more enclosures and configurations, please contact your local authorized Polk Audio dealer. We hope that this manual has helped to take the mystery out of designing an enclosure for your new Polk Audio EX Subwoofers.

AMPLIFIER POWER REQUIREMENTS

Your speakers will work well with a variety of electronic components. As little as 50 watts per channel will deliver adequate listening levels in most cars. If you have a noisy car or intend to play your system at loud listening levels, more power is necessary to achieve the best performance. More power is always better. Consult your Polk Audio dealer for specific recommendations.

SAFE LIMITS OF OPERATION

Your Polk loudspeakers are made with the highest quality materials for years of trouble-free performance. However, damage to loudspeakers can occur when an amplifier, regardless of its wattage, is made to play at higher listening levels than its power can clearly produce (usually beyond the “1 to 2 o’clock” position on the volume control).

This results in very high levels of audible distortion, originating in the amplifier, which adds a harsh, gritty sound to the music. Contrary to popular belief, a speaker is more likely to be damaged by trying to get too much volume from a low-powered amp than from a high-powered one.

LOW FREQUENCY CUT - OFF FOR SYSTEMS WITH SUBWOOFERS

Now that you have a subwoofer in your system, you may want to decrease the amount of bass going to your mid-range speakers. This will get you better midrange sound and increase the power handling. There are two ways to roll off the bass before it gets to the mid-range speakers. One way is to use a “bass blocker”, a capacitor placed in series with the main input. The other route is to use an electronic crossover device which allows filtering below 100 Hz or so.

TECHNICAL ASSISTANCE

Good luck and enjoy your new Polk EX Series II Subwoofers. If you need assistance or have any questions, call 1-800-377-POLK (7655) between 9am and 5pm, Monday through Friday Eastern Time.

EX SERIES II SUBWOOFER SPECIFICATIONS

	EX8	EX10	EX12
<u>THIELE/SMALL PARAMETERS</u>			
Type	subwoofer	subwoofer	subwoofer
Driver Complement	8"	10"	12"
Nominal Impedance	4ohms	4ohms	4ohms
Frequency response	20-300Hz	20-400Hz	20-500Hz
Fs (Hz)	44.64Hz	32.47Hz	24.47Hz
Re	3.73 ohms	3.34 ohms	3.38 ohms
Le	1.57 mH	1.55 mH	1.40 mH
Qms	11.43	8.27	8.14
Qes	0.57	0.48	0.31
Qts	0.54	0.45	0.30
Vas (cubic feet)	0.66 ft ³	1.59 ft ³	4.72 ft ³
Vas (liters)	18.51L	44.56L	132.02L
Power Handling (watts continuous)	125watts	150watts	150watts
Power Handling (watts peak)	300watts	400watts	400watts
Sensitivity (SPL at 1 watt / 1 meter)	90 dB	92 dB	93 dB
Xmax (inches)	0.177 in.	0.177 in.	0.177 in.
Xmax (millimeters)	4.5 mm	4.5 mm	4.5 mm
Voicecoil Diameter	1.5 in.	2.0 in.	2.0 in.
Mounting depth (inches) top mount	3 7/8"	4 11/16"	5 3/8"
(millimeters)	85 mm	120 mm	135 mm
Mounting depth (inches) bottom mount	4 1/4"	5 1/16"	5 3/4"
(millimeters)	110 mm	130 mm	145 mm
Mounting diameter (inches)	7 1/8"	9 1/16"	10 7/8"
(millimeters)	180 mm	230 mm	276 mm
<u>RECOMMENDED ENCLOSURES</u>			
Sealed			
Sealed volume(cubic feet)	.5 ft ³	.65 ft ³	.95 ft ³
(liters)	14.2 L	18.4 L	26.9 L
Ported			
Ported volume(cubic feet)	.75 ft ³	1.0 ft ³	1.25 ft ³
(liters)	21.2 L	28.3 L	35.4 L
Port diameter (inches)	3 in.	3 in.	4 in.
(millimeters)	75 mm	75 mm	100 mm
Port length (inches)	10 1/4"	11 1/4"	12 5/16"
(millimeters)	255 mm	280 mm	305 mm
Tuning frequency (Hz)	45Hz	38 Hz	40 Hz
Bandpass			
Bandpass total volume (cubic feet)	1.1 ft ³	1.1 ft ³	1.5 ft ³
(liters)	31.1 L	31.1 L	42.4 L
Front chamber volume (cubic feet)	.70 ft ³	.50 ft ³	.75 ft ³
(liters)	19.8 L	14.2 L	21.2 L
Back chamber volume (cubic feet)	.38 ft ³	.60 ft ³	.72 ft ³
(liters)	10.8 L	17.0 L	20.4 L
Port diameter (inches)	3 in.	3 in.	4 in.
(millimeters)	75 mm	75 mm	100 mm
Port length (inches)	12 3/8"	9 7/8"	19 3/16"
(millimeters)	310 mm	250 mm	480 mm
Back chamber tuning frequency (Hz)	58 Hz	51 Hz	46 Hz

EX SERIES II 1 YEAR WARRANTY

Polk Audio, Inc. warrants the original purchaser only that this Polk Audio EX Series II Product (the Product) will be free from defects in materials and workmanship for a period of (1) one year from the date of original retail purchase from a Polk Audio Authorized Dealer. However, this warranty will automatically terminate prior to the expiration of the (1) one year period if the original retail purchaser sells or otherwise transfers the Product to any other party. The original retail purchaser shall herein after be referred to as "you." To allow Polk Audio to offer the best possible warranty service, please fill out the Product Registration Card(s) and send them to the Factory at the address provided in the Registration Card within (10) ten days of the date of purchase.

Defective Products must be shipped, together with a proof of purchase, prepaid insured to the Authorized Polk Audio Dealer from whom you purchased the Product, or to the Factory at the address given in this booklet. Products must be shipped in the original shipping container or its equivalent; in any case the risk of loss or damage in transit is to be borne by you. If, upon examination at the Factory or Polk Audio Authorized Dealer it is determined that the unit was defective in materials or workmanship at any time during the Warranty period, Polk Audio or the Polk Audio Dealer will, at its option, repair or replace this Product at no additional charge, except as set forth below. All replaced parts and Products become property of Polk Audio. Products replaced or repaired under this Warranty will be returned to you, within a reasonable time, freight prepaid.

This Warranty does not include service or parts to repair damage caused by accident, disaster, misuse, abuse, negligence, inadequate packing or shipping procedures, commercial use, voltage inputs in excess of the rated maximum of the unit, cosmetic appearance of the cabinetry not directly attributable to defects in materials or workmanship, or service, repair, or modifications of the Product which has not been authorized or approved by Polk Audio.

This Warranty is in lieu of all other expressed Warranties. If this Product is defective in materials and workmanship as warranted above, your sole remedy shall be repair or replacement as provided above. In no event will Polk Audio, Inc. be liable to you for any incidental or consequential damages arising out of the use or inability to use the Product, even if Polk Audio, Inc. or a Polk Audio Dealer has been advised of the possibility of such damages, or any other claim by any other party. Some states do not allow the exclusion or limitation of consequential damages, so the above limitation and exclusion may not apply to you. This Warranty gives you specific legal rights which may vary from state to state.

This warranty applies only to Products purchased in the United States of America, its possessions, and U.S. and NATO armed forces exchanges and audio clubs. The Warranty terms and conditions applicable to Products purchased in other countries are available from the Polk Audio Authorized Distributors in such countries.